

SELLICK

S SERIES



ROUGH TERRAIN FORKLIFT



6,000 - 12,000 lb. Capacity

Tier 4 Diesel Engine

Rugged

Dependable

Responsive

 Powered by **T4**
ecoMAX

S S E R I E S - 6,000, 8,000, 10,000, 12,000 LBS CAPACITIES @ 24" LOAD CENTER

Standard specifications

The S Series straight mast rough terrain forklift provides optimum operator visibility, safety and comfort while maximizing machine performance. The one-piece frame welded construction offers rugged durability. The isolated, rubber-mounted operator's compartment is designed to reduce noise and vibration. Operators benefit from greater fork visibility and control. All controls and instrumentation are close at hand.

Engine



Ecomax T4

74 hp, direct injection, common rail, electronic, 4 cylinder diesel engine exceeds Tier 4 Final compliant emissions standards.

- No Diesel Particulate Filter (DPF) needed. Ultra clean burn technology allows for no Selective Catalyst Reduction (SCR) exhaust aftertreatment.
- Reduced fuel consumption.¹
- High torque at low speeds (295 ft. lbs @ 1,200 rpm).

Transmission

Four-speed (3-speed in S120 models) fully synchronized torque converter with power reversing integral parking brake. Optional fully automatic powershift.

Axles

Drive: Pad-mounted rigid planetary axle, torque proportioning four-pinion differential, gears are specially-shaped to transfer torque between wheels. Positive retraction brakes.

2WD Steer: Pin-mounted, oscillating axle with sealed tapered roller bearings. Oscillation: 14°

Optional 4WD Steer: Outboard planetary with torque proportioning differential. On the go engagement

Steering

Load sense power steering with hydraulic pump assistance.

Steer turns: 4.5 lock to lock.

Electrical system

Voltage: 12 V; alternator: 95A; battery: 1000 CCA.

Operator compartment

Fully isolated, floating operator's compartment exceeds ANSI/ITSDF B56.6 ROPS/FOPS standard. Adjustable suspension seat with retractable seatbelt, tilt steering column, cup holder, coat hook, latched operator's manual compartment, Operator's Manual, safety decal package.

Brake system

Service brake: Power-assisted braking system with enclosed oil-immersed multi-disc service brakes.

Parking brake: Independent parking brake system, mechanical-operated, lever-applied, manually-adjusted caliper, mounted on transmission output shaft.

¹Up to 10% reduced fuel consumption over T4i Interim engine.

Instruments



Multi-function Digital LCD Screen

- Fuel Level
- Engine Coolant Temperature
- System Voltage
- RPM and Hour Meter Reading
- On board diagnostics reduces downtime

Backlighting provides better visibility in dark conditions. Instrument panel swings forward for easy access to fuse panel.

Hydraulics

Hydraulic system powered by cast iron load sense hydraulic gear pump. A positive-pressure hydraulic tank prevents impurities from entering the system.

Tank capacity: 21 gallons (79 L)

Hydraulic flow rate: 24 gpm @ 2200 rpm

Mast assemblies

Sellick SEE-THRU® all-roller design. Two and three-stage available. Mast sideshift: 6" total.

Carriages

ITA hook or shaft-type carriages equipped with 6 rollers and 4 side thrust rollers.

Standard features

- Adjustable suspension seat
- Tilt steering column
- Retractable seatbelt
- Fuel/water separator
- Power assisted enclosed wet multi-disc brakes
- Load sense power steering
- Halogen lighting package includes two front and two rear adjustable worklights
- Safety lighting includes LED brake lights & amber warning light
- Backup alarm
- Automotive style park brake with neutral interlock
- Neutral safety start

Optional Equipment

- Cab
- Air conditioning
- Hydraulic fork positioner
- Turn signals
- Mirrors
- AM/FM MP3 player



TECHNICAL SPECIFICATIONS

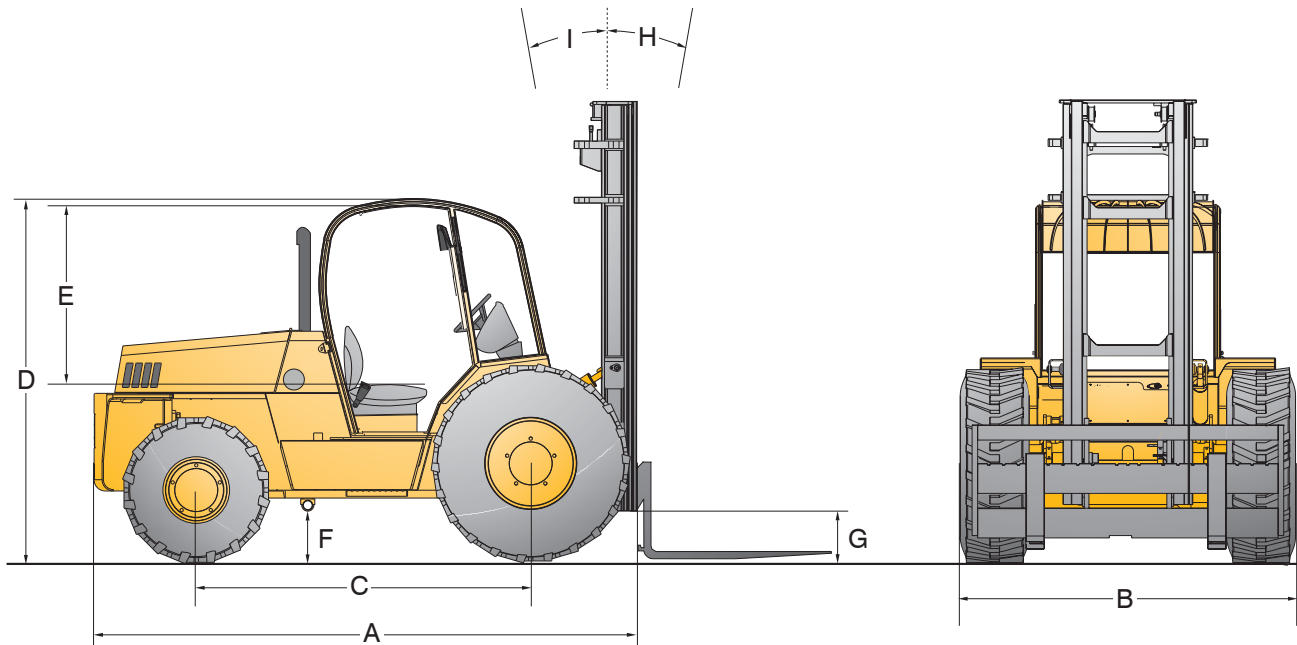

	Ref.	S60	S80	S100	S120
Lift capacities @ 24 inch load center		6,000 lbs	8,000 lbs	10,000 lbs	12,000 lbs
Total weight ²		14,855 lbs	16,235 lbs	19,245 lbs	20,915 lbs
Overall length (without forks)	A	149"/3,785 mm	150"/3,810 mm	152"/3,861 mm	159"/4,039 mm
Overall width	B		89"/2,261 mm		
Wheelbase	C		89"/2,261 mm		
Height to top of overhead guard (standard)	D		97"/2,464 mm		
Distance from seat to overhead guard (standard)	E		43"/1,092 mm		
Outside turning radius			178"/4,521 mm		183"/4,648 mm
Aisle width 90° stacking			266"/6,756 mm		271"/6,883 mm
Frame underclearance	F		15"/381 mm		
Mast underclearance	G		12"/305 mm		
Mast sideshift			6"/152 mm		
Mast tilt - forward	H		45°		
Mast tilt - rearward	I		12°		
Travel speed (standard)			19 mph		12 mph
Gradeability			25%		
Tire type & size (standard)		Drive (pneumatic) - 15.5 x 25 - 12 ply Steer (pneumatic) - 14 x 17.5 - 14 ply			
Engine model		ECOMAX T4			
Cylinders		4			
Engine output (gross power)		74 hp @ 2,200 rpm			
Peak torque		295 ft. lbs @ 1,200 rpm			
Transmission type		Power reversing synchromesh			

Because of our constant dedication to product improvement, all specifications are subject to change without notice.
 — All Sellick forklifts meet or exceed all ANSI/ITSDF B56.6-2016 safety standards —

²Total weight with standard operator's platform, 144" 2-stage mast, and load backrest.



Sellick

Working for you

Built in the Sellick tradition of quality & reliability, the S Series is supported by a network of long-established material handling dealers that provide prompt parts and service. All Sellick products are backed by one of the best warranties in the business.

All Sellick forklifts meet or exceed all ANSI/ITSDF B56.6-2016 safety standards.



Sold & serviced by:



Dillon

TOYOTA LIFT